

F. C. BRECKENRIDGE.
 TRANSMITTER.
 APPLICATION FILED DEC. 6, 1919.

1,377,144.

Patented May 3, 1921.

FIG. 1.

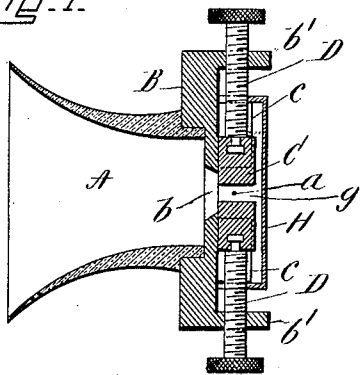

FIG. 2.

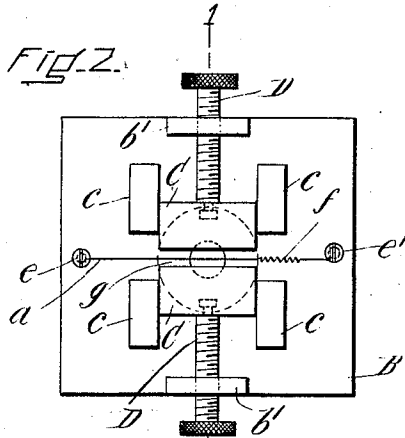

FIG. 3.

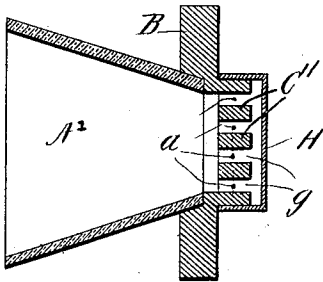

FIG. 4.

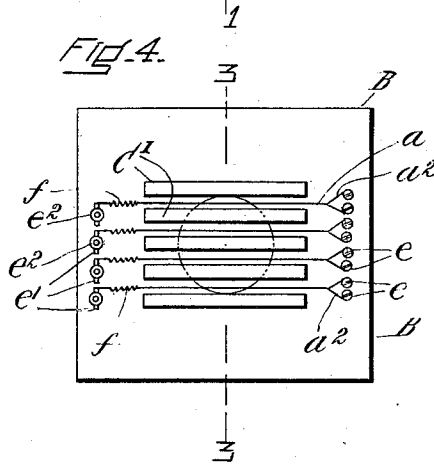

FIG. 5.

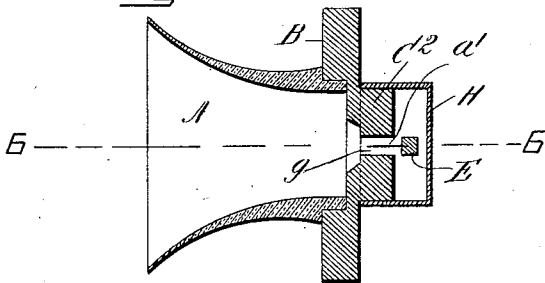

FIG. 6.

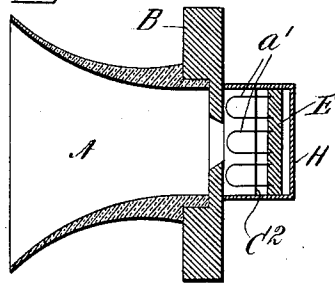

FIG. 7.

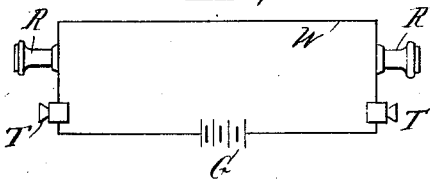
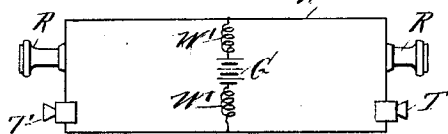

FIG. 8.



INVENTOR:
 Francis L. Breckenridge
 BY *Wm. H. ...* ATTORNEYS:

UNITED STATES PATENT OFFICE.

FRANCIS C. BRECKENRIDGE, OF PROVIDENCE, RHODE ISLAND, ASSIGNOR TO AMERICAN THERMOPHONE COMPANY, OF BOSTON, MASSACHUSETTS, A CORPORATION OF MASSACHUSETTS.

TRANSMITTER.

1,377,144.

Specification of Letters Patent.

Patented May 3, 1921.

Application filed December 6, 1919. Serial No. 343,010.

To all whom it may concern:

Be it known that I, FRANCIS C. BRECKENRIDGE, of Providence, in the county of Providence and State of Rhode Island, a citizen of the United States, have invented a new and useful Improvement in Transmitters, of which the following is a specification.

This invention relates to the transformation of sound waves in air into undulatory electrical waves by causing such sound waves to act upon a fine wire in an electric circuit. Such action changes the resistance of the wire so that electrical waves of considerable amplitude result in the circuit with such rapidity that the component waves required in the transmission of speech are transformed with sufficient faithfulness to make possible the transmission of articulate speech. For this purpose I have made a telephone transmitter, using a hot wire or wires which in volume and quality of the transformed wave is comparable with the carbon transmitter in common use today.

In the development of my transmitter it is desirable to subject the current-varying member or members (*i. e.*, the wire or wires of my device) to the greatest possible variations of air pressure, in order to produce the desired clearness of articulation; and to have all portions of the surface of the wire in a homogeneous thermo-dynamic state at any instant of time. It is this feature of my invention which I believe to be a distinct advance in the art. Such a device as I describe hereafter is an improvement over other forms of transmitter in that there is no poor contact in the circuit as is the case in all microphones. My transmitter is in consequence not subject to disturbing effects such as packing or burning, which are characteristic of most microphones. Moreover, I believe this transmitter is especially adapted for use in those cases where a current of very high frequency is varied as in wireless telephony or telegraphy or in multiplex telephony where "carrier" currents of high frequency are used.

In the drawings I have shown various improvements embodying my invention, but I do not mean to limit myself merely to the constructions shown.

Figure 1 is a section taken on line 1—1 of Fig. 2.

Fig. 2 is a rear elevation of the form of

apparatus shown in Fig. 1, the back of the device being removed.

Fig. 3 is a section on line 3—3 of Fig. 4.

Fig. 4 is a rear view of the apparatus shown in Fig. 3.

Figs. 5 and 6 show another form of my invention, these figures being sections taken on lines at right angles to one another.

Figs. 7 and 8 show arrangements of circuits suitable for use with this device.

The wire used in connection with this apparatus is of as small a gage as can be conveniently handled, and in Figs. 1, 2, 3 and 4 such wire is shown at *a*. In Figs. 5 and 6 wires are shown in the form of loops *a*¹. In each case the device is provided with a mouthpiece A of usual character except that the mouthpiece A¹ in Fig. 3 is preferably made rectangular.

Referring to Fig. 1, the mouthpiece A sets into a plate B having an opening *b* leading to the wire chamber and carrying lugs *b*¹ projecting rearwardly. *U*, *C* are slides running in guideways *c* and each having connected thereto a screw D passing through one of the lugs *b*¹ and thus serving as a convenient means of adjustment of the slot in which the wire *a* is mounted. The wire *a* is stretched between screws *e*, *e*¹, there being a spring *f* in the wire intermediate the screws *e*, *e*¹ as a means of keeping the wire under tension. These screws *e*, *e*¹ may serve as binding posts for the necessary electrical connections.

When the wire is heated it expands, and in order to keep it taut and always in parallel relation to the walls of the slot, some means such as the spring *f* is desirable in most cases. The slot *g* between the members C should best be adjustable in width so that it may meet the peculiarities of any particular instrument, and this adjustment should be so made that the wire will pass through the slot at equal distances from the walls thereof. H is a cup-shaped back which fits over and closes in the rear of the instrument. It serves to form a resonating chamber within which is the wire *a*, which tends to equalize the pressure of the air upon all sides of the wire, and is preferably adjustable in order to change the size of the resonance chamber.

In Figs. 3 and 4 the parts are similarly lettered so far as they are like the parts in

Figs. 1 and 2. In this case, however, there are a plurality of wires a , and the slots g are formed between fixed partitions C^1 . As a means of insuring the proper centering of the wires a between the partitions C^1 , each wire is connected at one end to a loop a^2 , the ends of the loop being attached to two adjusting screws e . Either end of the loop may thus be lengthened or shortened as may be necessary to center the wire. Each wire a is provided with an elastic or spring portion f , which in turn is connected to a pin e^1 projecting from the screw e^2 . Moreover, adjustment at either end is usually sufficient for the purpose. These adjustments may be alike at each end of the wire, or other adjustments may be used if thought best.

In the place of the wire a a thin foil of conducting material may be used, its thin edge being directed toward the source of sound, the broad surfaces being parallel to the sides of the slots.

In Figs. 5 and 6 the wires, which in this case are marked a^1 , are formed in loops and are so mounted that the greatest width of the loops lies in a plane parallel to the sides of the slot. In this case springs such as f are not needed as when the loops expand they should still remain parallel to the sides of the slots.

In this case the loops are mounted on a support E located back of the slot and in the resonance chamber so that the loops project into the slot. The loops may be connected either in series or in multiple depending upon whether the circuit with which the transmitter is connected is of high or low resistance.

The circuit used with this instrument may be of any of those forms commonly used in telephony. Such circuits as are shown in Figs. 7 and 8 have been used with good effect. In these views the transmitter is lettered T , the receiver R , the battery G and the wire W . In Fig. 8 the battery G is projected across between the wires W in series with a split coil W^1 of high impedance and low resistance. Other circuits may be used,

such as for example the common telephone circuit with induction coil.

In practising this invention there have been used successfully fine platinum wires of $2\frac{1}{2}$ microns in diameter made from Wolaston wire.

It will be obvious to one skilled in the art that other arrangements of wire a may be used and yet come within the scope of the claims of my invention hereinafter made.

What I claim as my invention is:—

1. A current-varying device comprising an extremely thin conductor, an inclosure therefor having a slotted opening, said conductor being mounted in said opening, and means whereby variations of air pressure may be directed thereto.

2. In a current-varying device of the kind described, an extremely thin conductor and an inclosure therefor having a slotted opening in which said conductor is mounted, the walls of said inclosure being adjustable whereby the width of said slot may be adjusted.

3. A current-varying device comprising an extremely thin conductor and an inclosure therefor forming a resonance chamber having a slotted opening said conductor being mounted between the walls of said opening, and means for adjusting the size of said resonance chamber.

4. A current-varying device comprising an extremely thin conductor and an inclosure therefor forming a resonance chamber having a slotted opening in which said conductor is mounted, the walls of said inclosure being adjustable whereby the width of said slot may be adjusted, and means for adjusting the size of said resonance chamber.

5. A current-varying device comprising an extremely thin conductor, yielding means for keeping it taut, and means for mounting it whereby a maximum variation of air pressure and a substantially homogeneous thermo-dynamic state may exist at every portion of the conductor at any instant of time.

FRANCIS C. BRECKENRIDGE.