

April 27, 1926.

1,582,194

B. TRIVUS

DETECTOR

Filed August 12, 1925

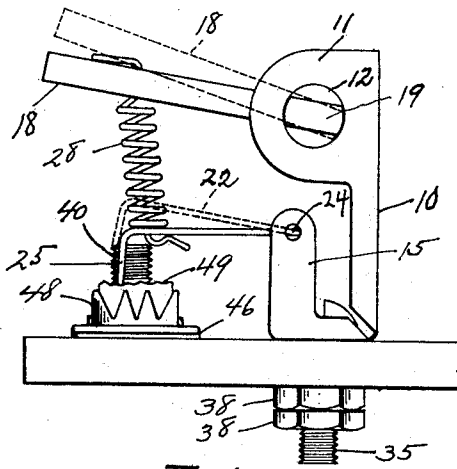

Fig. 1

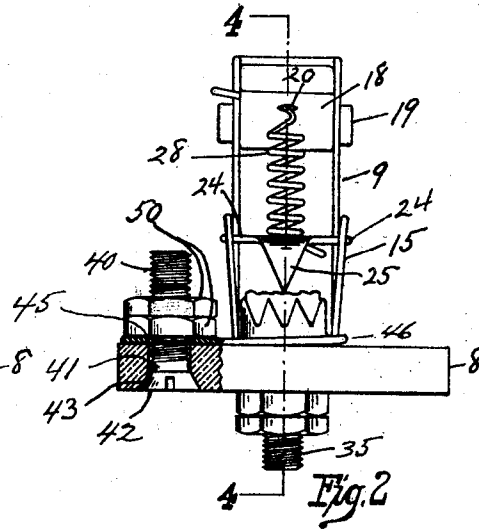

Fig. 2

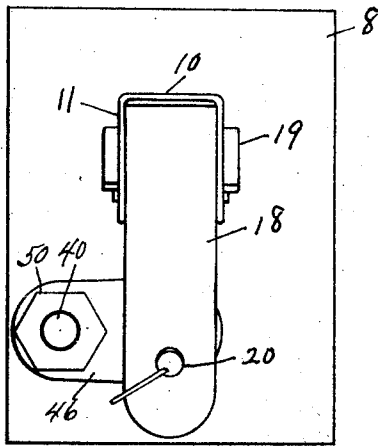

Fig. 3

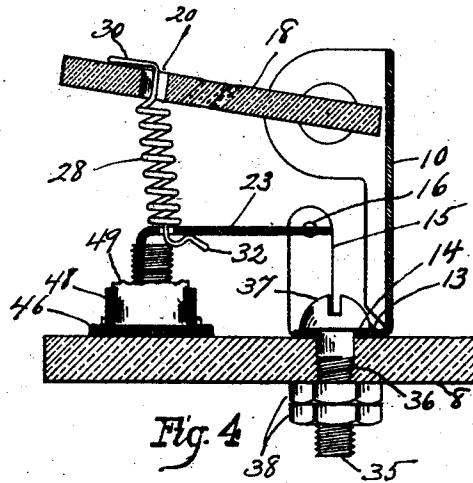

Fig. 4

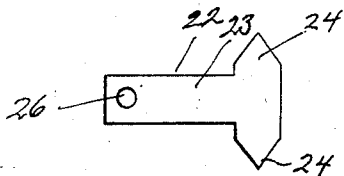

Fig. 5

Inventor
Benjamin Trivus
By Horatio E. Bellome
Attorney

UNITED STATES PATENT OFFICE.

BENJAMIN TRIVUS, OF PROVIDENCE, RHODE ISLAND.

DETECTOR.

Application filed August 12, 1925. Serial No. 49,832.

To all whom it may concern:

Be it known that I, BENJAMIN TRIVUS, a citizen of the United States, residing at Providence, in the county of Providence and State of Rhode Island, have invented certain new and useful Improvements in Detectors, of which the following is a specification.

My invention relates to detectors for wireless telegraphy and telephony of the crystal type and has for its essential objects delicacy of adjustment; freedom from derangement, and inexpensiveness of construction.

To the above ends essentially my invention consists in such parts and in such combinations of parts as fall within the scope of the appended claims.

In the accompanying drawings which form a part of this specification—

Figures 1, 2, and 3 are a side elevation, a front elevation, and a top plan view respectively of a detector embodying my invention,

Figure 4, a section of the same on line 4—4 of Figure 2; and

Figure 5, a detail plan view of the contact member.

Like reference characters indicate like parts throughout the views.

My device in its present and preferred form of embodiment comprises a base or panel 8 of insulating material carrying a standard 9 of stamped and bent metal comprising a vertical strip or body 10, forwardly directed lateral lugs 11 upon its upper portion provided with holes 12, a forwardly directed foot 13 resting against the base 8 provided with an opening 14, and vertical ears 15 integral with the sides of the foot 40 provided with perforations 16.

A supporting arm 18 of hard rubber or other insulating material has near one end lateral lugs or trunnions 19 fitting in the holes 12 with such a degree of friction that, although circular movement or partial rotation therein is possible, yet the plate 18 will remain at any angle to which it may be manually tilted. The arm has a hole 20.

A contact member 22 stamped and bent from sheet metal is provided comprising an arm 23 provided with lateral pivot members 24 upon its rear end registering in the perforations 16, and upon its forward end a pointer 25 directed downwardly at right angles to the arm. The arm has near the pointer a hole 26.

A helical spring 28 has its upper end extending through the hole 20 with its extremity 30 laterally bent forming a finger resting on the upper face of the plate 18. The lower end of the spring passes through the hole 26 and has its extremity laterally bent to form a finger 32 engaging and supporting the arm 23.

A screw 35, which is one terminal, extends through the opening 14, and a hole 36 in the base. The head 37 of the screw rests upon the foot 13. The body of the screw 35 carries the usual nuts 38 for clamping therebetween the end of one circuit wire. The second terminal consists, in this instance, of a screw 40 in a hole 41 in the base. This screw has a beveled head 42 countersunk, as at 43, and passes through a hole 45 in a plate 46 resting on the base. This plate, pivoted as described, has upon its top face a holder 48 in which is a mass of sensitized or crystalline material 49, upon the upper surface of which the pointer 25 is adapted to contact clamping nuts 50 on the screw 40 and adapted to engage the second wire of the circuit.

The operation of my device is as follows. The arm 18 may be grasped by its free end by the operator and be moved upwardly or downwardly carrying the contact member 22 which it supports through the spring 28 along with it as shown in broken lines in Figure 1. In applying the pointer 25 of the needle to the crystalline mass 49 the arm 18 is manually downwardly pressed forcing the member 22 downwardly, but with a greater degree of delicacy through the spring 28 so that any fine degree of pressure upon the crystalline mass 49 may be attained with ease and certainty.

I claim:—

1. In a device of the character set forth, a base of insulating material, a crystalline mass on the base, a metallic standard on the base, a supporting arm of insulating material pivotally attached to the standard and provided with a hole, a metal arm pivotally carried at one end by the standard provided with a hole, a pointer upon the other end of the arm disposed at an angle to the second arm adapted to engage the mass, and a helical spring having its ends engaging the two arms through the two holes.

2. In a device of the character set forth, a base, a crystalline mass on the base, a metal standard comprising a body, a foot

upon the body resting upon the base, lateral lugs upon the upper portion of the body provided with holes, and parallel lateral lugs upon the foot provided with perforations, a
5 metal screw in the foot extending into the base, a supporting arm of insulating material, trunnions on one end of the arm frictionally engaging in the holes, a metallic arm, pivot members integral with one end

of the second arm registering in the per- 10
forations, a pointer on the other end of the second arm disposed at an angle to the latter and adapted to rest on the mass, and a spiral spring having its ends attached to intermediate portions of both arms. 15

In testimony whereof I have affixed my signature.

BENJAMIN TRIVUS.