

Aug. 23, 1927.

W. H. ADAMS

1,640,172

INDUCTION COIL FOR RADIO APPARATUS

Filed Oct. 1, 1923

2 Sheets-Sheet 1

Fig. 1.

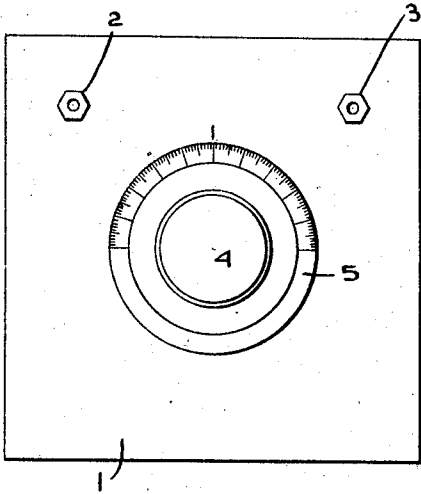

Fig. 2.

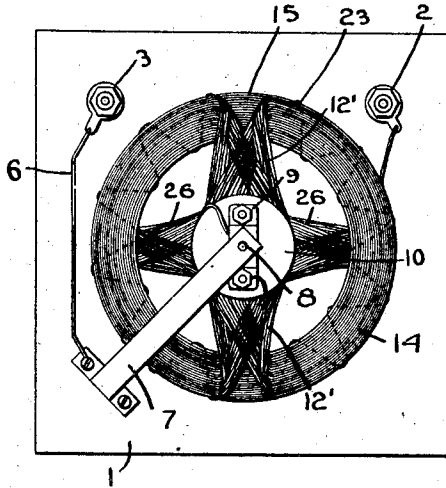

Fig. 3.

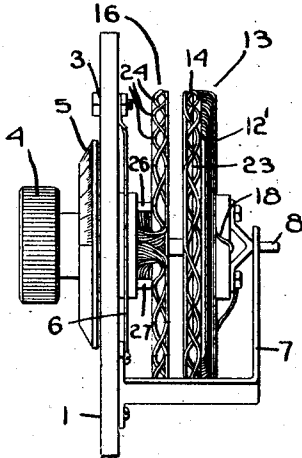

Fig. 4.

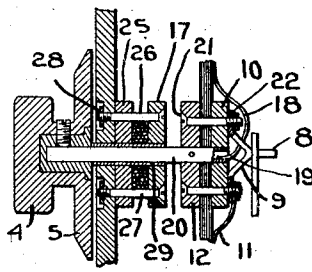

Fig. 6.

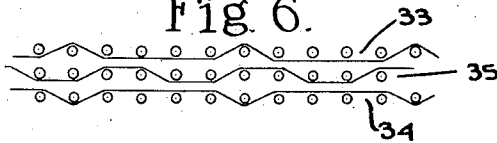
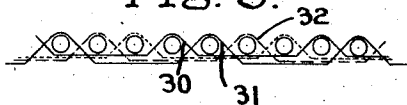

Fig. 5.



Inventor:  
William H. Adams  
by *Harold Smith & Tennant.*  
Attys.

Aug. 23, 1927.

1,640,172

W. H. ADAMS

INDUCTION COIL FOR RADIO APPARATUS

Filed Oct. 1, 1923

2 Sheets-Sheet 2

Fig. 7.

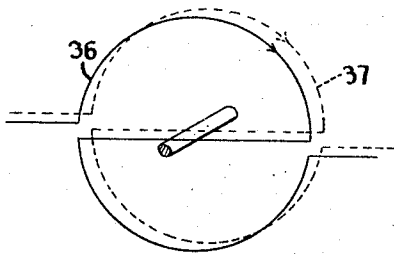

Fig. 8.

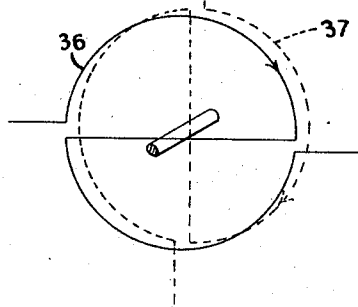

Fig. 9.

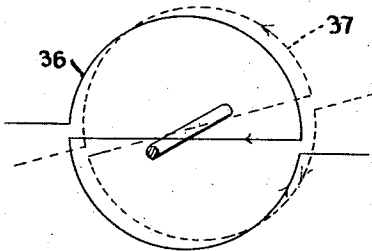

Fig. 11.

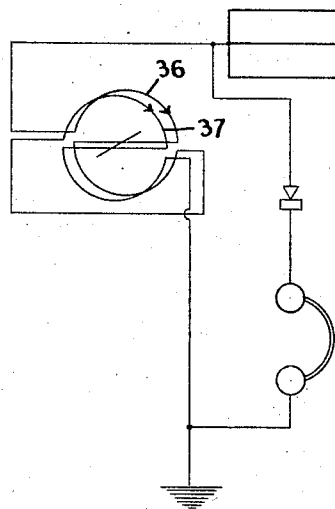
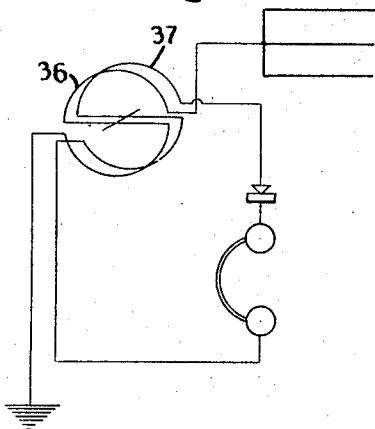

Fig. 10.



Inventor:  
William H. Adams  
by *Harold Smith & Tennant.*  
Attys

## UNITED STATES PATENT OFFICE.

WILLIAM HUSSEY ADAMS, OF KENYON, RHODE ISLAND.

## INDUCTION COIL FOR RADIO APPARATUS.

Application filed October 1, 1923. Serial No. 666,014.

This invention relates to an apparatus such as a tuning coil for radio apparatus. In receiving messages from various sending stations using different wave lengths in transmitting, it is necessary to have some means of tuning the receiving set so that only the waves sent out by a certain particular station may be received, and the waves sent out by other stations may be eliminated. The two ordinary and most frequently used means of tuning are, first, a variable capacity usually taking the form of a variable condenser, and second, a variable inductance.

This invention has to do particularly with a variable induction coil. The ordinary induction coil has in general two parts, a movable coil and a stationary coil which are permanently wound on forms. These coils present difficulties when in use in that the supporting material of the form acts as a capacity which affects the easy tuning of the instrument, particularly if the capacity, as is usually the case, happens to be unevenly distributed. The usual forms of coils are also unsatisfactory in that the supporting material for the wires possesses some magnetic or diamagnetic properties and, with the high frequency used in transmitting radio waves, causes a proportionately large hysteresis loss. Loose coupling is a difficulty with this type of coil, but the possibility of varying the coupling from tight to loose is an advantage in eliminating interference. The possibility of retaining the inductance balance and loosening the coupling by separating the coils axially is a valuable quality.

The object of the invention is to provide a coil with a very low and evenly distributed capacity.

The object of the invention is further to provide a coil comprising circumferential and diametrical windings in which the circumferential portions support one another without the aid of a form and are in turn supported almost entirely by the diametrical portions.

The object of the invention is further to provide a coil having a minimum of any material near the windings which might have a condensing or capacity effect.

The object of the invention is further to provide a coil having fixed and movable members wound in radial planes and adjustable to vary the mutual inductance by

rotation in said planes and to vary the strength of coupling between the parts by varying the axial distance between such radial planes, without varying the total resistance of the circuit.

The drawings illustrate both diagrammatically and in detail preferred forms of construction adapted for use in radio receiving stations and embodying the broad principles of the invention.

In the drawings;

Fig. 1 is a front elevation of a preferred form of construction embodying the invention, showing the mounting panel, binding posts, dial and knob;

Fig. 2 is a rear elevation of the construction shown in Fig. 1;

Fig. 3 is a side elevation of the construction shown in Fig. 1;

Fig. 4 is a sectional view taken axially through the coil 4;

Figs. 5 and 6 are diagrammatic views illustrating the various types of winding;

Figs. 7, 8, and 9 are diagrammatic views showing the movable coil in several positions with arrows to indicate the direction of current flow when used as a variocoupler;

Fig. 10 is a diagrammatic view showing the device used as a variocoupler.

Fig. 11 is a diagrammatic view showing the device connected as a variometer.

The instrument thus shown as a simple and preferred form of the invention consists of the usual panel 1, having mounted on its front face binding posts 2, 3 and a knob 4 with its associated graduated dial 5.

On the rear of the panel are the coils with their associated connections and supports. Connection is made from the binding post 3 by means of wire 6 to one of the screws with which the bracket 7 is mounted on the rear of the panel. In the end of the bracket is a hole serving as a bearing point in which rests the rear end 8 of the contact 9 attached to the rear block 10 of the rear coil. From the contact a wire 11 leads to the circumference of the coil. In place of the friction contact at the rear of the rear coil, spring or pig-tail or other flexible conducting contact can be used. In fact all the coil connections can be effected through such pigtail or flexible connections and the coupling or metallic sleeve and shaft connection omitted. This becomes necessary when the two coils are used for variocoupler effect. The coils are wound on temporary spokes and temporary centers around the

central spool which latter can be made in parts as shown or may be an integral insulating spool grooved to accommodate and hold the diametral cross over members.

5 The coil is wound in a temporary disk or ring around the front hub block, 12, of the rear coil. In the winding operation the wire is drawn in and out around the spokes in any manner, but preferably so that it takes the form illustrated in either Fig. 5 or Fig. 6. 10 After the wire has thus been interlaced with the spokes through substantially one half the circumference, it is brought across the diameter and into engagement with the periphery of the hub; thence in a similar manner it is interlaced through the temporary spokes for substantially the other half the circumference and brought back across the diameter, again engaging the periphery and crossing the first diametrical wire 12', between the hub and the circumference. In a similar manner the winding of the coil is continued until the desired series of similar windings have been completed. As the circumferential windings are put in place the circumferential portions, by reason of the interlacing of the temporary spokes, are crossed transversely of the plane of the coil, and the wires constituting the mass or assembly of the diametrical portions cross at opposite sides of the hub between the hub and the circumference, engaging the side of the hub periphery and thus forming a firm support for themselves and for the circumferential portions of the coil. For clearness in the drawing the diametrical wires have been shown in Fig. 3 as lying in back of the movable coil. The wire is finally led around and across the hub as illustrated at 18, scraped bare of insulation and electrically connected, as at 19, to the axle 20, which is of electrically conducting material. After the coil has been thus wound the bolts 21 are drawn tight by means of the nuts 22 thereby clamping in position that portion of the diametrical wires lying between the front and rear hub blocks unless a spool shaped single piece center is used, in which latter case the wires are embedded in the groove.

50 A further and desirable, but not essential step in forming the coil is to interlace fine threads 23 in a radial direction parallel with, and next to, the openings which must necessarily be left in the interlacing of the wires around the spokes during the winding process. These threads may be inserted in any manner which will assist in holding the circumferential wires in position when the spokes are withdrawn.

60 For example the threads may be run from the outer edge of the coil down through one of the openings beside one of the spokes, thence across a bottom circumferential wire, up the next opening parallel to the next spoke, thence across a top circumferential

wire to the next opening, down that opening to the bottom of the coil, across and up to the next opening and so on, as illustrated at 23 in Figs. 2 and 3; or the threads may simply form a loop passing down the opening parallel with the spokes and up on the outer face of the coil as illustrated at 24, in Fig. 3.

The fixed coil is wound in the same manner and its rear and front hub blocks 17 and 25 respectively are drawn tight on the diametrical wires 26 by means of bolts 27 acting in conjunction with nuts 28 bearing against the mounting panel. A connection is made from one of the coil end wires of the fixed coil to the electrically conducting sleeve 29, and after the coil has been wound the final connection of the other coil end wire is made to the binding post 2 on the panel.

After the winding of each coil is completed it is preferably stiffened by applying a suitable binding, insulating and stiffening material. This may be put on to the coil in any desired manner, as by dipping the coil in the stiffening material such, for example, as shellac or lacquer, spraying or painting it on. After this material has thoroughly dried, the temporary spokes and temporary disk or ring around the hub disk on which the coil was originally wound are withdrawn, leaving the coil self-supporting and supported from the hub only by the diametrical wires.

The instrument in this invention comprises a plurality of relatively movable coils, preferably one or more fixed coils and a single movable coil. The movable coil illustrated is firmly connected to the axle 20 which passes through a sleeve 29 serving as a support for the axle. This sleeve is supported by the panel 1 and also by the hub blocks of the fixed coil. The axle is both slidable longitudinally through, and rotatable in, the sleeve. Thus by means of the knob on the front of the panel a rotary motion may be transmitted through the axle 20 and hub blocks 10 and 12, to the diametrical wires, 12', and therefrom to the circumferential wires 14. The movable coil also may be moved axially by either pushing or pulling the knob in order to change the setting of the coil from a close coupled to a loose coupled position. In order to give any further adjustment of the instrument which may be necessary taps may be taken in the usual manner from either or all of the coils, but as such taps are old in the art they have not been illustrated and will not be further described.

In assembling the instrument, an insulating hub with removable spokes is first provided, and the coil is wound on the spokes in the manner herein before stated. The windings are then tied together with the binding threads, the coil is coated and after

the coating has hardened the spokes are withdrawn leaving the coil self-supported. If the coil under construction is to be a fixed coil, the hub is mounted on the panel by means of the bolts, and one end of the wire is connected to the binding post, 2, on the panel and the other end to the electrically conducting sleeve 29 or to a pigtail connection. If the coil under construction is to be the movable coil, the hub may be provided already mounted on the axle with the rear contact in place. One end of the wire is then connected to the rear contact or to a pigtail connection, the coil is wound, and then the other end of the wire is connected to the axle or to a pigtail connection.

Although the method just described is preferable to any others, it may be convenient to wind the coil on a temporary form, stiffen it, remove it from the form, mount it on the permanent hub, and connect it in the circuit.

Fig. 5 illustrates one form of winding for a coil embodying the invention. This form may be termed a "three and one winding" since the section of winding lying on the face of the coil nearest an adjacent coil passes in front of three winding spokes and around one spoke. The windings will have the form of that indicated at 30. All of the windings are supposed to lie behind one another in the same plane and parallel to the spokes, but for clearness of illustration windings 31 and 32 have been shown with the face wires standing farther from the spokes than they are in the actual finished coil.

Fig. 6 diagrammatically illustrates a form of winding on a coil having two outer fixed coils 33, 34 and a central movable coil, 35. The type of coil used on the outer fixed coil may be termed a "four and one winding" since that portion of the winding lying on the face of the coil passes in front of four spokes, and around one spoke.

The type of winding shown on the central movable coil may be termed a "two and two winding" since that portion of the winding lying on either face of the coil passes two spokes.

The object of using the four and one winding is to get as much wire as possible on the face of the coil next to the adjacent coil and as little as possible behind the face or in the cross overs. The cross overs are necessary and important, however, because the crossed over portions bind and strengthen the coil rendering it self-supporting and also serve as the portions of the winding about which the binding threads, when used, are passed.

Fig. 7 is a diagrammatic showing of the coils in full maximum inductive coupling such as is also illustrated diagrammatically in Figs. 10 and 11. The arrows on the coils

show the direction of current flow when the fixed and movable coils are connected in series as shown in Fig. 11. When the coils are in the position thus shown and drawn together as closely as possible they are in mutual reinforcement, that is the coils are as closely coupled as possible and one coil is affecting the other to the greatest possible extent and in the same direction.

When the coils are in the position shown in Fig. 8 they are in minimum inductive coupling. The fixed coil is designated at 36 and the moving coil at 37. The coils may be further adjusted by moving the movable coil in an axial or longitudinal direction, thereby obtaining additional tuning. The arrows in this figure denote the direction of current flow when the coils are connected in series as a variocoupler.

In Fig. 10 the device is hooked up as a variocoupler with the fixed coil 36 and the movable coil 37 in separate coils in maximum inductive coupling. When the movable coil 37 is rotated through 90° from this position the two coils are in the position of minimum inductive coupling of the two circuits.

In the hook up illustrated diagrammatically in Fig. 11 the fixed coil 36 and the movable coil 37 are connected in series as a variometer and the current flow in the windings will have the direction indicated by the arrows and the inductance of the circuit will be at the maximum because the two coils are in a position of mutual reinforcement but by rotating the movable coil 37 through 180° in reference to the fixed coil 36 the induction of the circuit will be at a minimum because in this position the two coils are in a position of mutual opposition.

Having thus described my invention, what I claim as new, and desire to secure by Letters Patent, is:

1. A coil for a radio apparatus comprising an insulating hub and a series of similar windings each extending through substantially one half the circumference of the coil, thence across the diameter, thence in the reverse direction through the other half of the circumference and back across the diameter, the circumferential portions of different terms being crossed transversely of the plane of the coil and the diametrical portions engaging the hub and crossing each other between the hub and the circumference whereby the coil is supported wholly by the hub.

2. A coil for a radio apparatus comprising an insulating hub and a series of similar windings each extending through substantially one half the circumference of the coil, thence across the diameter, thence in the reverse direction through the other half of the circumference and back across the diameter, the diametrical portions engaging the hub

and crossing each other between the hub and the circumference whereby the coil is supported solely from the hub.

3. A coil for a radio apparatus comprising a series of similar windings each extending through substantially one half the circumference of the coil, thence across the diameter, thence in the reverse direction through the other half of the circumference, and back across the diameter, an axial supporting element dividing the diametric windings and constituting the sole support for said coil.

4. A coil for radio apparatus consisting of a continuous conducting winding in the form of a flat double D, a supporting ele-

ment situated axially of said coil, the several circumferential portions of the winding crossing each other across the plane of the coil and the diametrical portions which connect the circumferential turns crossing each other in the plane of the coil and passing alternately on either side of said supporting member, said circumferential portion being supported entirely by the diametrical portion and the axial support constituting the sole support for the axial portions.

In testimony whereof I have signed my name to this specification.

WILLIAM HUSSEY ADAMS.