

Jan. 1, 1952

J. L. ENTWISTLE ET AL

2,581,180

APPARATUS FOR STRIPING WIRE

Filed Feb. 9, 1949

3 Sheets-Sheet 1

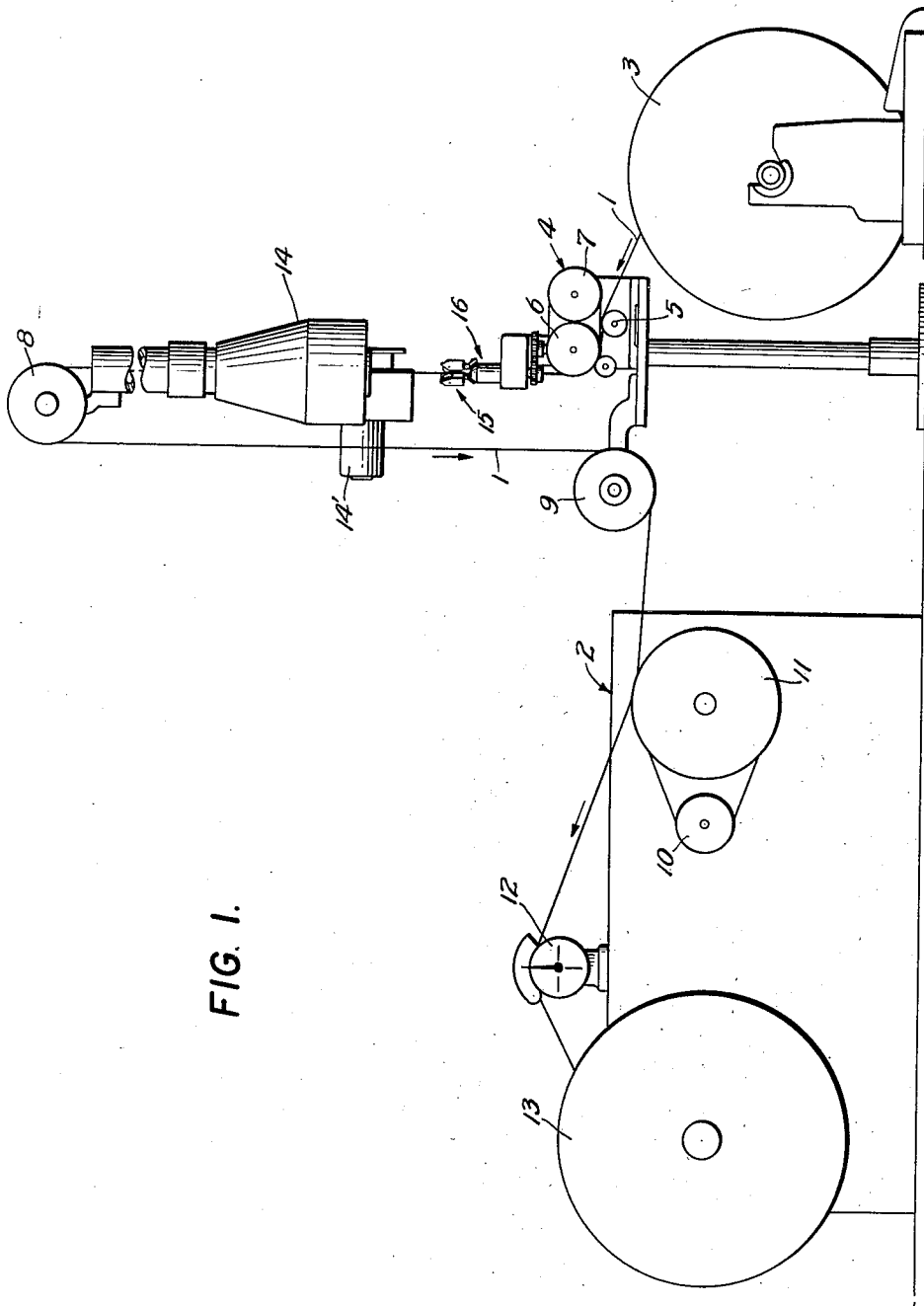

FIG. 1.

INVENTOR
JAMES L. ENTWISTLE
ALDEN W. NELSON
BY *Paul Kolisch*
ATTORNEY

Jan. 1, 1952

J. L. ENTWISTLE ET AL

2,581,180

APPARATUS FOR STRIPING WIRE

Filed Feb. 9, 1949

3 Sheets-Sheet 2

FIG. 2.

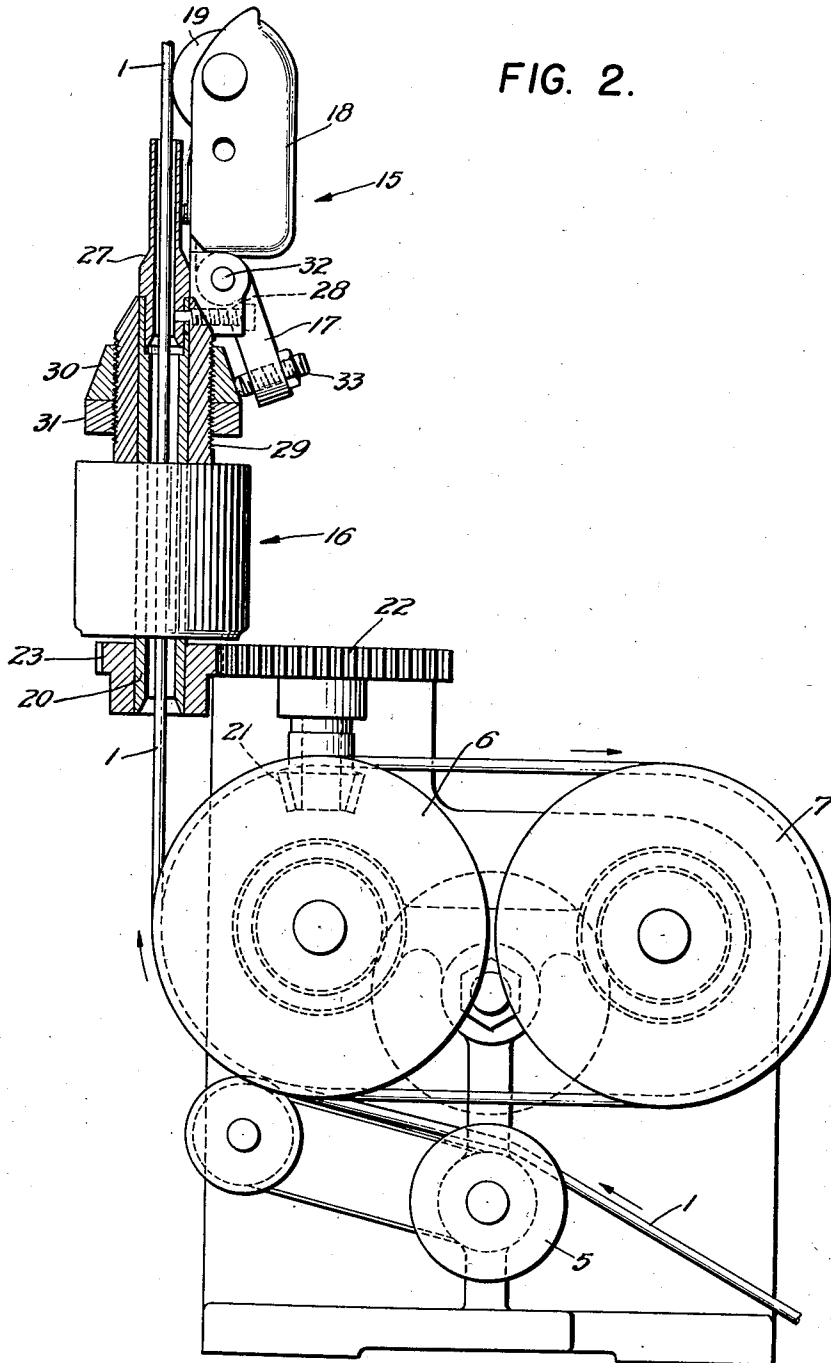

INVENTOR
JAMES L. ENTWISTLE
ALDEN W. NELSON
BY *Paul Kolisch*
ATTORNEY

Jan. 1, 1952

J. L. ENTWISTLE ET AL
APPARATUS FOR STRIPING WIRE

2,581,180

Filed Feb. 9, 1949

3 Sheets-Sheet 3

FIG. 3.

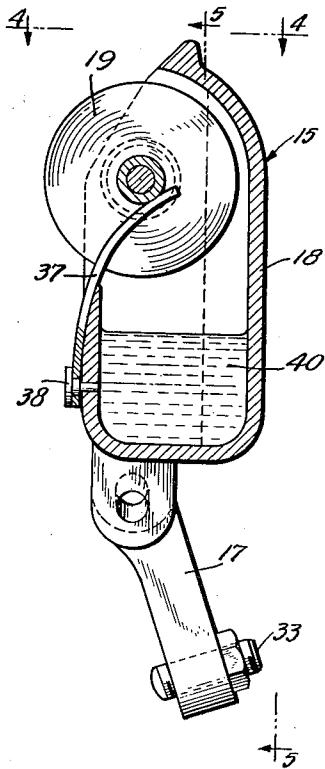

FIG. 4.

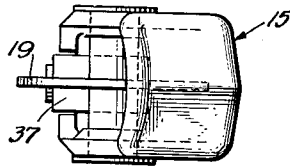

FIG. 5.

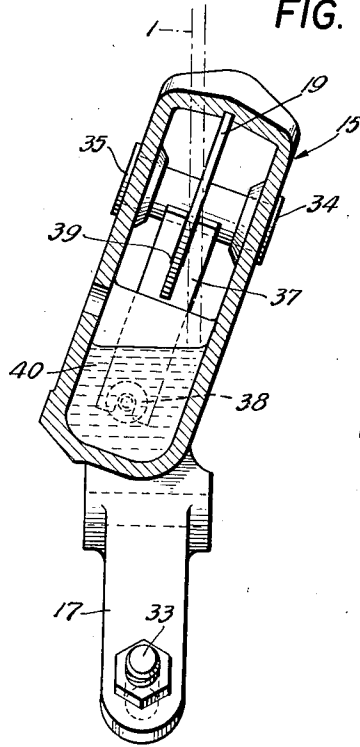
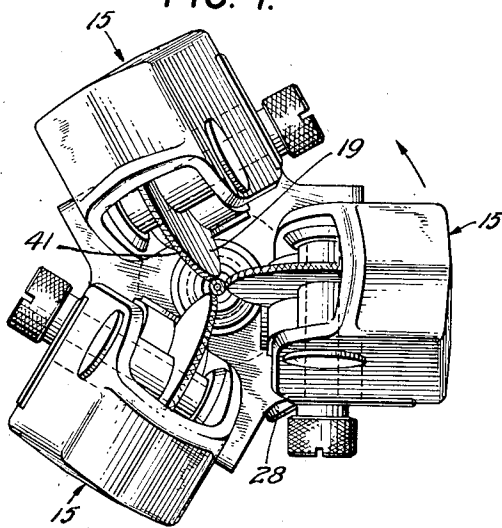

FIG. 6.



FIG. 7.



INVENTOR
JAMES L. ENTWISTLE
ALDEN W. NELSON
BY *Paul Kohuch*
ATTORNEY

UNITED STATES PATENT OFFICE

2,581,180

APPARATUS FOR STRIPING WIRE

James L. Entwistle, Cranston, and Alden W. Nelson, Pawtucket, R. I., assignors to The James L. Entwistle Co., Pawtucket, R. I., a copartnership composed of James L. Entwistle and Margherita C. Entwistle

Application February 9, 1949, Serial No. 75,422

4 Claims. (Cl. 91-12)

1

The present invention relates to an apparatus for marking a cylindrical body and more particularly to an apparatus for applying stripes to the insulation surrounding wires for conducting electricity.

In many cases, e. g. communication equipment, it is desirable to be able to distinguish different wires from one another. Commonly in such equipment when the wire insulation is of plastic or rubber, each distinctive wire must be extruded a different solid color. If the insulation is of fabric, distinctively colored strands must be embodied as part of the covering. It is therefore necessary for a user to keep in stock large quantities of distinctively colored wire. This is both inconvenient and expensive.

According to our invention it is possible for the wire user to keep wire in stock, all of whose insulation may be the same color, and as needed, by means of a novel marking head, apply distinguishing marks such as different colored spiral stripes to the insulation. It will be appreciated that according to this method of marking wire it will be possible distinctively to mark an almost infinite number of wires. For instance the eight basic colors may be used in all sorts of combinations either as marking stripes or as different base colors of the insulation itself.

The object of the present invention, therefore, is to provide an apparatus which applies spiral stripes to wire insulation.

A feature of the present invention is that spiral stripes of different colors may be applied to insulated wires.

Another feature of the present invention is an apparatus in which an insulated wire is pulled in one direction and controls the rotation of a marking head around the wire.

Still another feature of the present invention is a marking head comprising one or several individual marking units, each unit being partly filled with a suitably colored ink which is applied to the wire by a rotatable wheel.

These and other features of the present invention will become apparent from the following description taken in conjunction with the accompanying drawings, in which:

Fig. 1 is a schematic side elevation of the apparatus;

2

Fig. 2 is a side elevation partly in section of the capstan drive of the marking head;

Fig. 3 is a side elevation partly in section of a marking unit;

Fig. 4 is a top plan view of Fig. 3 on lines 4-4;

Fig. 5 is a section on the lines 5-5 of Fig. 3;

Fig. 6 shows a piece of the wire with spiral marking stripes; and

Fig. 7 is a top plan view of the marking head with three marking units.

In the embodiment of Fig. 1, wire 1 is pulled by a conventional capstan drive generally indicated at 2 from a pay-off drum 3 over pulleys 5, 6, 7 of a capstan drive generally indicated at 4. Wire 1 is then pulled over pulleys 8 and 9 by capstan wheels 10 and 11 and traversed onto take-up drum 13 by guide wheel 12. On its way from pulley 6 to pulley 8 the wire moves along the vertical center line of a marking head generally indicated at 16 and through a drying device 14. When pulleys 6 and 7 are rotated by wire 1, marking head 16, which is connected by suitable gears to these pulleys, is rotated around the wire.

Marking head 16 comprises one or more marking units 15 each of which comprises a lower portion 17 (Fig. 3) for adjustably mounting the unit on head 16, and an upper portion or reservoir 18, which is partly filled with a colored liquid, such as ink, and houses a rotatable marking wheel 19. Wheel 19 contacts wire 1 at an acute angle and as it is rotated by the moving wire transports the liquid from the reservoir to the wire and applies a spiral stripe to the latter.

Capstan drive 4 for rotating marking head 16 is schematically shown in Fig. 2. Wire 1 is pulled over pulleys 5, 6 and 7 by capstan drive 2 (Fig. 1) in the direction indicated by the arrows and then moves through a hollow shaft 20. As pulleys 6 and 7 are driven by the wire, a bevel gear 21 driven by a meshing bevel gear on the shaft of pulley 6 (not shown) rotates with a gear 22 which meshes with a gear 23 on shaft 20. Thus the rotation of hollow shaft 20 around wire 1 is controlled by the wire.

The upper portion of hollow shaft 20 (Fig. 2) is telescoped by another hollow shaft 27 which keeps wire 1 in the center of hollow shaft 20. Both these hollow shafts are rigidly held together by a screw 28. Fulcrum hub 29 is press fitted around hollow shafts 20 and 27 and two lock nuts

3

30 and 31 are screwed on a threaded portion of fulcrum hub 29. Lock nut 30 is tapered.

A unit 15 is adjustably mounted on fulcrum hub 29 in the following manner: A pivot 32 fastens the bottom of reservoir 18 to fulcrum hub 29. A threaded lug 33 passes through a hole in the bottom of lower portion 17 and contacts tapered lock nut 30. Unit 15 is moved closer to wire 1 by tightening screw 33 and moved away by loosening the screw. In this manner the distance between wheel 19 and wire 1 may be varied. This distance may also be varied by screwing lock nuts 30 and 31 up or down on fulcrum hub 29. Accordingly, if it is necessary to adjust the distance between the units and wire 1, because wire of different diameter from that previously used, is employed, the adjustment on all the units may be simultaneously performed by operating lock nuts 30, 31.

Wheel 19 contacts wire 1 (Fig. 5) at an acute angle so that a true rolling action along the spiral angle of the stripe is obtained. The wheel is rotatably mounted (Figs. 3, 4, 5) in reservoir 18 by means of bearings 34, 35 on either side of the reservoir. An opening is provided in the front of the reservoir through which wheel 19 protrudes. A scraping device 37, conveniently made of chemically resistant synthetic rubber, is held on the front of reservoir 18 by a headed stud 38, and contact with hub of marking wheel 19. The lower half of wheel 19 passes through a slit 39 in the scraper. The sides of the slit scrape against the wheel to wipe off any liquid adhering thereto. It is desirable that the liquid be only on the rim of the wheel which contacts the wire in an acute angle substantially as shown in Fig. 5. The unit forms this angle with the wire because lower portion 17 is in a different plane from upper portion 18 when the unit is mounted on fulcrum hub 29.

Reservoir 18 is partly filled with a colored liquid 40, e. g. ink. As long as unit 15 is not rotating the level of the liquid is below wheel 19. When the unit rotates the liquid will be forced outward and bank up vertically on the closed side of reservoir 18 by centrifugal force so that wheel 19 dips in the ink, as shown by dotted lines (Fig. 3). We have found that when the head rotates at an optimum speed of 1200 R. P. M. it is well above the necessary speed to centrifuge the ink to a vertical position in the reservoirs. Since the wheel is free to rotate and contacts wire 1 it transports the ink to the wire and marks a spiral stripe on the latter. If the head rotates too fast the type of marking ink commonly used will separate and be unusable. Since the back and top of reservoir 18 are closed, a high piling up of liquid 40 is possible. It is advisable to fill reservoir 18 as high as possible, e. g. until just below the opening in its front.

The rim of wheel 19 is preferably knurled as at 41 (Fig. 7) so that liquid will better adhere to the wheel. The sides of wheel 19 are preferably smooth and are kept clean by the operation of scraper 37 as above described.

The width of a spiral stripe depends upon the width of the contacting surface of wheel 19 and may be varied by varying the width or the shape of the rim of wheel 19.

The pitch of the spiral marked on the wire depends on the speed of rotation of the marking head which will depend on the rate at which the wire is pulled through the head. When the head rotates at 1200 R. P. M. and the wire is travelling at about 165 feet per minute, a pitch of 1.69 inches will be obtained on wires between $\frac{3}{64}$ and $\frac{1}{8}$

4

inches in diameter. However, the apparatus is not limited to such diameters or pitches and wires of different diameters may be used in combination with any desired value for the pitch which may be obtained by varying the velocity of wire 1 and/or head 16.

Head 16 preferably comprises three individual marking units 15. The units are similarly mounted on the head at equal distances from one another. Fig. 7 shows a top view of head 16 with three units 15 mounted on it.

Each reservoir 18 may be filled with a different colored ink. Thus, there will be marked on the wire three equally spaced colored spiral stripes. If desired the stripes may all be of the same color or only one or two stripes may be marked on the wire by leaving one or two reservoirs dry.

Fig. 6 shows a length of spirally marked wire such as would be obtained if head 16 comprising three equally spaced units 15 were rotated at 1200 R. P. M. with wire 1 travelling at about 165 feet per minute. A distance of approximately .56 inch between the stripes would be obtained.

After being marked wire 1 is pulled through a drier 14 (see Fig. 1) and a blower 14' blows a stream of air into drier 14 where it is heated and dries the markings on the wire.

While we have described a preferred embodiment of the invention, other modifications and embodiments will be suggested to those skilled in the art and it is intended to limit the invention only by the appended claims.

What is claimed is:

1. A marking head for a wire striping machine comprising a single enclosed, smooth walled oblong structure for striping fluid, and having an opening in the upper half of the front wall at the juncture with the top, and a wheel rotatably mounted in the reservoir with its rim protruding through said opening and closely adjacent the inner back surface of the reservoir's wall, a plurality of said reservoirs mounted around the wire with which the wheels are in cooperative relation, a mounting bracket pivotally connected at one end to the bottom of each reservoir, an externally threaded hub surrounding the wire, an internally threaded nut having a tapered shoulder and movable on said hub, and a lug extending from the other end of each of said mounting brackets to engage said tapered shoulder whereby when said internally threaded nut is moved the position of said reservoirs with respect to the wire will be changed.

2. A marking head for a wire striping machine comprising an oblong reservoir enclosed except for an opening near the top, a rotatable wheel on a pivot mounting supported by the reservoir wall, the rim of said wheel protruding through the opening into cooperative relation with the wire and closely adjacent the inner back surface of the reservoir wall, and a pivotally supported mounting supporting said reservoir, the axis of said pivot being transverse to the direction of movement of the wire, means to adjust said mounting about said pivot, whereby said reservoir may be adjusted to vary the position of the wheel and reservoir with respect to the wire.

3. The apparatus according to claim 2, in which a plurality of said reservoirs are pivotally supported on pivots transverse to the axis of said wire, and a single movable means for adjusting in unison the positions of all reservoirs with respect to the wire to vary the engagement of each of said wheels and the wire.

4. A marking head for a wire striping machine

5

comprising a reservoir having a smooth continuous inner wall, enclosed except for an opening near the top, a rotatable wheel on a pivot mounting supported by the reservoir wall, the rim of said wheel protruding through the opening into cooperative relation with the wire and closely adjacent the inner back surface of the reservoir wall, and a pivotally supported mounting supporting said reservoir, the axis of said pivot being transverse to the direction of movement of the wire, means to adjust said mounting about said pivot whereby said reservoir may be adjusted to vary the position of the wheel and reservoir with respect to the wire.

JAMES L. ENTWISTLE.
ALDEN W. NELSON.

15

6

REFERENCES CITED

The following references are of record in the file of this patent:

UNITED STATES PATENTS

Number	Name	Date
1,960,228	Milmoe -----	May 22, 1934
2,157,874	Webb -----	May 9, 1939
2,344,610	Hargreaves -----	Mar. 21, 1944
2,537,884	Forsberg -----	Jan. 9, 1951

10